

Discrete I/O

P/N: DIO128

12 inputs, 8 relay outputs, SAE J1939

with Electronic Assistant® 

Description:

The Discrete I/O Module reads 12 discrete inputs and sets 8 Form C relay outputs while providing a simple interface between a SAE J1939 CAN network and other electronic devices on a machine. The unit is an automotive battery powered device with the ability to withstand engine cranking, reverse polarity and transient power conditions. In engine applications, information is provided to the engine control system using single-frame J1939 application-specific PDU2 type messages. Outputs can be controlled by any input or CAN messages. A bi-color LED indicates operational status.

The DIO128 has a number of setpoints that allow the user to configure it for their application. The *Windows*-based Electronic Assistant™ can be used to configure the module using the CAN line. Alternatively, a RS-232 interface allows for quick user configuration adjustments using Windows HyperTerminal or other similar terminal software. Settings are saved to non-volatile memory upon command. The setpoints can also be saved to a file and flashed into other DIO128 modules over the CAN bus.

Ruggedly packaged with watertight Deutsch IPD connectors, the I/O module is suitable for use in harsh environments. Units are UL and cUL recognized to UL508 and C22.2 No. 142-M1987.



Applications:

- Power Generator Sets
- Diesel Engine Control Systems

Ordering Part Numbers:

SAE J1939 version
Controller: DIO128
Mating Plug Kit: AX070200 (8 pin and 40 pin, no key)
AX070502 Configuration KIT includes the following. USB-CAN Converter P/N: AX070501 1 ft. (0.3 m) USB Cable P/N: CBL-USB-AB-MM-1.5 12 in. (30 cm) CAN Cable with female DB-9 P/N: CAB-AX070501 AX070502IN CD P/N: CD-AX070502, includes: Electronic Assistant® software; EA & USB-CAN User Manual UMAX07050X; USB-CAN drivers & documentation; CAN Assistant (Scope and Visual) software & documentation; and the SDK Software Development Kit. NOTE: To order this kit, you need only to specify P/N: AX070502.

Technical Specifications:

Block Diagram

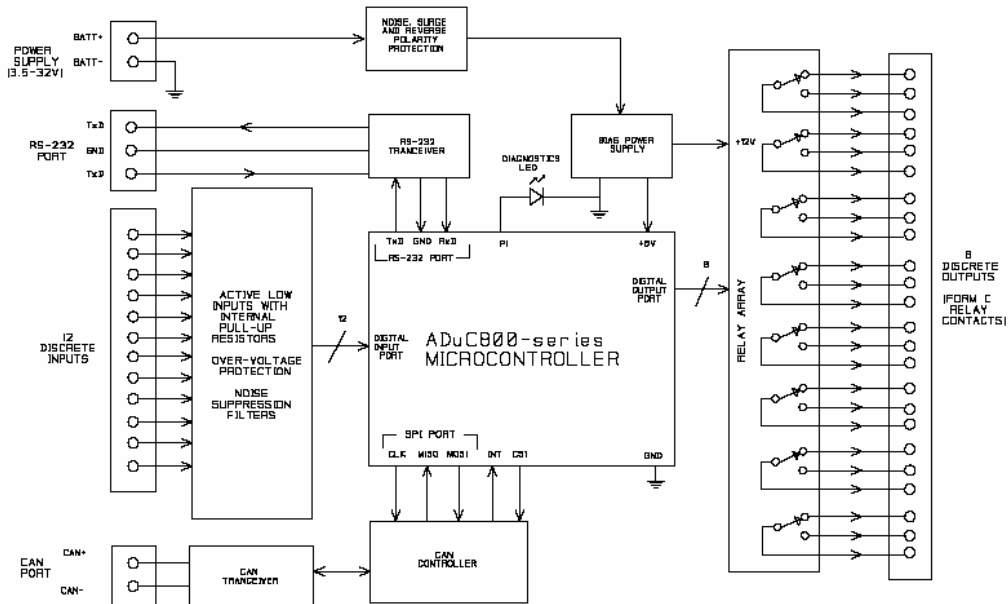

Inputs and Outputs

- Modules are designed for mounting on power generator sets or remotely up to 30 ft.
- Multiple DIO128 modules can be used on a CAN network.
- Reads twelve (12) discrete inputs (active low with pull-up resistors)
- Input level characteristics:
Low-Level input voltage: 0 to 0.8 V
High-Level input voltage: 3.75 to 24V
Inputs have internal pull-up resistors.
- 4 Digital GND connections are provided.
- Sets eight (8) Form C relay outputs rated for resistive loads of 2A@30Vdc, 2A@125Vac and 2A@277Vac for Normally Closed (NC) relays or 2A@30Vdc, 2A@125Vac and 2A@277Vac for Normally Open (NO) relays. For inductive loads, the ratings are 0.5A@250Vac $\cos\phi=0.4$, 1A@250Vac $\cos\phi=0.8$, 0.8A@250Vac $\cos\phi=0.9$.
- The DIO128 can operate in one of four different modes: Normal Mode (CAN); Discrete Mode; Fault Mode; or Disabled Mode. Refer to the user manual for details.
- In Normal Mode, there are four ways the output can be configured to respond to the state of the control input (discrete input or CAN message): disabled; normal ON/OFF; inverted ON/OFF; or latched (changes state every time the control input transitions from OFF to ON). In Discrete Mode the relays can only be controlled by a discrete input wired to the module (no CAN). In Fault Mode, the relay is driven to a particular state. In Disabled Mode, all output relays are de-energized.
- In Normal Mode, each output has four setpoints associated with it that determine the control input, control response, enable input and enable response for that relay. In Discrete Mode, there are an additional 2 setpoints for Control Input and Enable Input.
- Converts between physical I/O and CAN (SAE J1939) single frame commands
- Maximum level of current draw of 400mA + 50mA per energized relay @ 12Vdc
- Isolation voltage: 4000 Vac (rms), 50/60 Hz for 1 min. between coil and contacts, 750 Vac, 50/60 Hz for 1 min. between contacts of the same polarity
- A 3A fast-acting fuse is recommended for installation external to the device.
- LED indicator remains RED when a network error occurs. It flashes green when the module is able to send messages over the bus but there is no network activity detected by the module. It stays ON and is GREEN when it is operating normally and is powered.
- **Electronic Assistant®**  runs on a Windows operating system for user configuration. An Axiomatic USB-CAN converter links the PC to the CAN bus.

Power Supply

- Accepts 8...32VDC power (12 or 24VDC nominal)
- Overvoltage capability is 32VDC for 1 hour @ 85°C
- Reverse polarity protection is provided.
- Power supply input section protects against transient surges and short circuits and is isolated from I/O inputs

Regulatory Compliance

- UL and cUL recognized to UL508 and C22.2 No. 142-M1987
- Certified as a component for use in other equipment
- Suitable for use in non-hazardous locations
- Suitable field wiring for the rated voltage and current must be used.
- The installation must meet applicable electrical codes suitable for the jurisdiction. This device does not provide energy-limited circuits.
- The unit carries an IP65 rating without an enclosure for non hazardous locations.
- $-40^{\circ}\text{C} \leq T_{\text{amb}} \leq 70^{\circ}\text{C}$ ($-40 \leq T_{\text{amb}} \leq 158^{\circ}\text{F}$)
- Must be installed with Deutsch IPD mating plugs, DT06-8SA and DRC16-40SB or DRC18-40SB for the supply receptacle and the I/O interface receptacle, respectively.
- Rating of connection cables must be at least 70°C
- Use field wiring suitable for both minimum and maximum ambient temperature.
- The end user must provide an overcurrent protection device rated at a minimum 32VDC, maximum 3A.

General Specifications

- Quiescent current draw is 46 mA @ 24VDC.
- Compact size (See mechanical drawing below.)
- 2.35 lbs. (1.07 kg)
- Packaged in a rugged aluminum housing with stainless steel end plates
- Watertight Deutsch connectors
- IP65 rating
- Suitable for moist, high shock and vibration environments
- Designed to be mounted directly on an engine without vibration isolators
- Operating temperature range of -40 to $+70^{\circ}\text{C}$ (-40 to 158°F)
- The ambient storage temperature range is -50°C to $+120^{\circ}\text{C}$ (-58 to 248°F).
- It is protected against 95% humidity non-condensing, 30°C to 60°C (86 to 140°F).

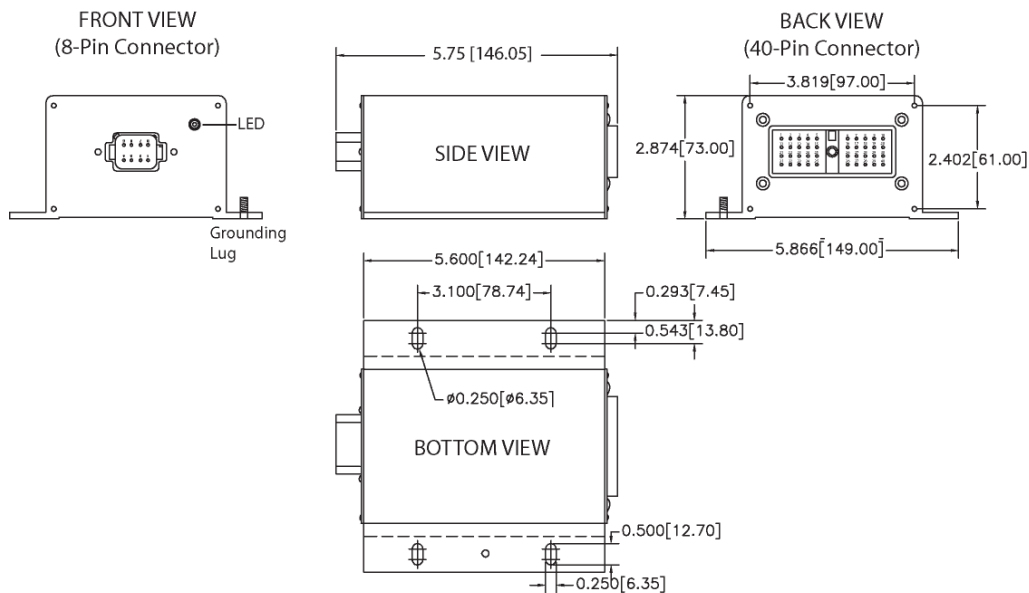

Dimensions: inches [mm]

Installation

Grounding	<p>Protective Earth (PE) must be connected to the grounding stud to reduce the risk of electric shock. The conductor providing the connection should have a ring lug and wire larger than or equal to 4 mm² (12 AWG). The ring lug should be placed between the nut and a star washer. (To secure the ground strap, use a 8-32 "K-LOK" locknut, stainless steel, 3/8" O.D.)</p> <p>All chassis grounding should go to a single ground point designated for the machine and all related equipment.</p> <p>The ground strap that provides a low impedance path for EMI should be a ½ inch wide, flat, hollow braid, no more than 12 inches long with a suitable sized ring lug for the module's grounding lug. It may be used in place of the PE grounding conductor and would then perform both PE and EMI grounding functions.</p>
Shielding	<p>The CAN wiring should be shielded using a twisted conductor pair. All wire shields should be terminated externally to the grounding lug on the mounting foot. The input wires should not be exposed for more than 2 inches (50 mm) without shielding. Shields can be ac grounded at one end and hard grounded at the opposite end to improve shielding. If the module is installed in a cabinet, shielded wiring can be terminated at the cabinet (earth ground), at the entry to the cabinet or at the module.</p>
CAN Wiring	<p>The CAN port is electrically isolated from all other circuits. The isolation is SELV rated with respect to product safety requirements. Refer to the CAN specification for more information.</p> <p>Use CAN compatible cabling. J1939 cable is recommended as it is rated for on-engine use.</p> <p>Shielded CAN cable is required. The module provides the CAN port shield connection ac coupled to chassis ground. The chassis ground stud located on the mounting foot must be tied directly to Earth Ground.</p>
Network Construction	<p>Axiomatic recommends that multi-drop networks be constructed using a "daisy chain" or "backbone" configuration with short drop lines.</p>
Termination	<p>It is necessary to terminate the network with external termination resistors. The resistors are 120 Ohm, 0.25W minimum, metal film or similar type. They will be placed between CAN_H and CAN_L terminals at both ends of the network.</p>
Mounting	<p>Mounting ledges include holes sized for ¼ inch or M6 bolts. The bolt length will be determined by the end-user's mounting plate thickness. Typically ¾ inch (20 mm) is adequate.</p> <p>If the module is mounted without an enclosure, it should be mounted vertically with connectors facing left and right to reduce likelihood of moisture entry.</p> <p>The CAN wiring is considered intrinsically safe. The power wires are not considered intrinsically safe and so in hazardous locations, they need to be located in conduit or conduit trays at all times. The module must be mounted in an enclosure in hazardous locations for this purpose.</p> <p>No wire or cable harness should exceed 30 meters in length. The power input wiring should be limited to 10 meters.</p> <p>All field wiring should be suitable for the operating temperature range of the module.</p> <p>Install the unit with appropriate space available for servicing and for adequate wire harness access (6 inches or 15 cm) and strain relief (12 inches or 30 cm).</p>

Network Communications Interface

The DIO128 is designed to work either as a stand-alone module, or on J1939 CAN network. When connected to the network, it automatically recognizes network connection, claims a network address and can be configured to perform the following application tasks:

- Continuously broadcasts the current state of digital inputs using a proprietary InputPGN
- Receives and processes OutputPGNs to control DIO output relays

Other features of the communications interface include:

- Has two configurable "slew rates" to accommodate different CAN (SAE J1939) connections (capable of working both on the standard J1939 link between an engine controller and a generator controller, and on a J1939 accessory module link from a generator controller in power generation applications).
- Other communication protocols are available on request (i.e. CANopen).
- Node address is auto configurable as per J1939-81 or per customer request.
- Includes a watchdog timer to require a reboot when the microprocessor locks
- Module is designed to remain powered up during engine cranking.
- Electronic Assistant®  runs on a Windows operating system for user configuration. An Axiomatic USB-CAN converter links the PC to the CAN bus.
- Alternatively, the RS-232 port can be used to communicate with PC-based data terminal software such as Tera Term.

SAE J1939 Profile

- Customer specific proprietary extensions can also be included in the SAE J1939 profile.
- Refer to the user manual for further details on the communications.

The network part of DIO128 is compliant with Bosch CAN protocol specification, Rev.2.0, Part A and B, and the following J1939 standards:

ISO/OSI Network Model Layer	J1939 Standard
Physical	<ul style="list-style-type: none"> • J1939/11 – Physical Layer, 250K bit/s, Twisted Shielded Pair. • J1939/15 - Reduced Physical Layer, 250K bits/sec, Un-Shielded Twisted Pair (UTP).
Data Link	<p>J1939/21 – Data Link Layer.</p> <p>DIO128 supports Transport Protocol for Commanded Address messages (PGN 65240). It also supports responses on PGN Requests (PGN 59904).</p>
Network	<p>J1939, Appendix B – Address and Identity Assignments.</p> <p>J1939/81 – Network Management.</p> <p>DIO128 is an Arbitrary Address Capable ECU. It can dynamically change its network address in real time.</p> <p>DIO128 supports: Address Claimed Messages (PGN 60928), Requests for Address Claimed Messages (PGN 59904) and Commanded Address Messages (PGN 65240).</p>
Transport	N/A in J1939.
Session	N/A in J1939.
Presentation	N/A in J1939.
Application	<p>J1939/71 – Vehicle Application Layer.</p> <p>It transmits Software ID PGN65242 (-SOFT) only on request.</p> <p>DIO128 can constantly transmits the state of digital inputs in a user defined PDU2 PGN, set to proprietary B PGN 65440 by default.</p> <p>DIO128 can receive user defined PDU2 PGN controlling output relays, set to 65448 by default.</p> <p>DIO128 can receive mode select commands or send mode status feedback in a user defined PDU2 PGN, set to proprietary B PGN 65456 by default.</p> <p>J1939/73 – Application Layer – Diagnostics.</p> <p>DIO128 uses Memory Access Protocol (MAP) for setpoint programming from the Electronic Assistant® </p>

Connections

Use the following Deutsch IPD mating plugs to connect to the integral receptacles. Wiring to these mating plugs must be in accordance with all applicable local codes. Suitable field wiring for the rated voltage and current must be used. The rating of the connecting cables must be at least 70°C. Use field wiring suitable for both minimum and maximum ambient temperature.

Receptacle	Mating Socket (Refer to www.laddinc.com for more information on the wedgelock and contacts for this mating plug.)
Power and CAN bus: DT13-08PA	DT06-08SA with wedgelock W8S
I/O Interface Receptacle: DRC13-40PB	DRC16-40SB DRC18-40SB

Power, CAN bus and RS-232

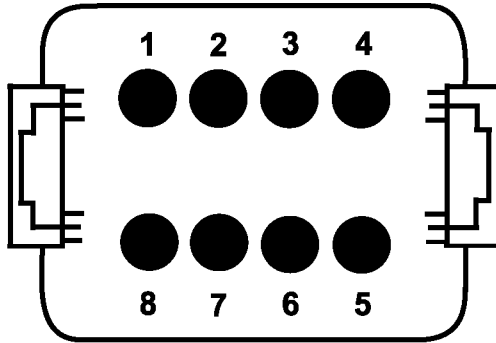

- 1 = PWR+ 5 = SHIELD
- 2 = CAN-H 6 = RS-232 GND
- 3 = CAN-L 7 = RS-232 TXD
- 4 = PWR- 8 = RS-232 RXD

**FRONT VIEW
MODULE MOUNTED CONNECTOR
DEUTSCH P/N: DT13-08PA**

(Mating plug is DT06-08SA with wedge W8S and sockets 0462-201-16141)

Connections – I/O

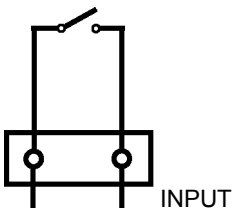

DIN GND

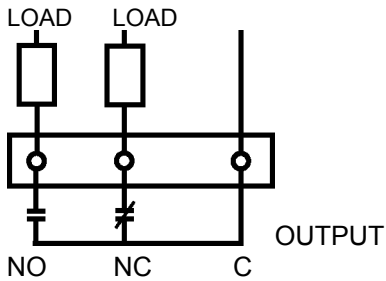

**FRONT VIEW OF
MODULE MOUNTED CONNECTOR
DEUTSCH P/N: DRC13-40PB**

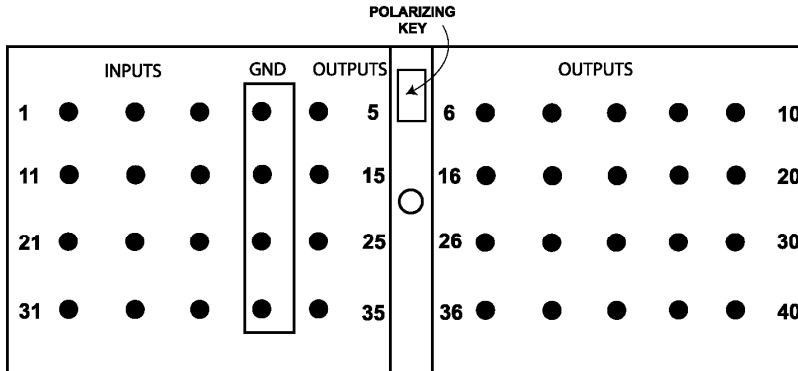

NO - Normally Open
NC - Normally Closed
C - Common

INPUTS	Pin	OUTPUTS	Pin
DIN1	1	NC_1	5
DIN2	11	C_1	6
DIN3	21	NO_1	7
DIN4	31	NC_2	15
DIN5	2	C_2	16
DIN6	12	NO_2	17
DIN7	22	NC_3	25
DIN8	32	C_3	26
DIN9	3	NO_3	27
DIN10	13	NC_4	35
DIN11	23	C_4	36
DIN12	33	NO_4	37
GND	4	NC_5	8
GND	14	C_5	9
GND	24	NO_5	10
GND	34	NC_6	18
		C_6	19
		NO_6	20
		NC_7	28
		C_7	29
		NO_7	30
		NC_8	38
		C_8	39
		NO_8	40

Mating Connector Part Number:

Deutsch IPD p/n DRC16-40SB or DRC18-40SB with sockets 0462-201-16141

Axiomatic offers a mating connector plug kit, P/N AX070200 that includes the 8 pin and 40 pin (unkeyed) plugs and sockets.

Specifications are subject to change without notice.
TDDIO128-12/19/08