

TECHNICAL DATASHEET #TDAX080200
24 to 24V DC Converter
240 Watts, Isolated
P/N: AX080200K

Clean 24VDC power in a rugged package...

- 24 to 24V DC Converter
- Input operating voltage range from 13 to 32VDC
- Conditioned output of 24VDC \pm 2%, 240VA
- No minimum load requirement
- Switch mode operation delivers high efficiency
- Reverse polarity protection
- Output short circuit protection
- Under and over input voltage protection
- Input and output isolation
- Robust, rugged and highly reliable
- Compact size for ease of mounting in confined spaces
- Connects via a 4-pin plug
- Suitable for moist, high shock and vibration environments
- Operational from -40 to +85°C
- IP67 protection



Applications:

SCADA Systems

Remote Terminal Units (RTU)

Switchgear

Motor Control Centers

Charging/Cranking Battery Based Power Supply Systems

Power Conditioning for Controls & Instrumentation utilizing DeviceNet or other industrial networks

Off-Highway Equipment Control Systems

Marine Auxiliary and Propulsion Systems

These applications are found in a variety of industries including process industries, general manufacturing, electric utilities, oil & gas, water/wastewater and mobile equipment.

Description: The DC-DC Converter provides clean 24VDC power suitable for instrumentation and control networks or process equipment. For operation under the most harsh and demanding conditions, the unit is fully sealed and enclosed to protect against moisture, shock and vibration. Power from a battery or other source in the range of 13-32VDC is converted to a 24VDC output regulated to 2%. Input and output isolation is provided. The unit is designed with extremely rugged surge and transient suppression in addition to sustained over/under voltage protection. With a nominal nameplate rating of 240VA of output power, the DC-DC Converter has a typical efficiency rated at 86%.

Ordering Part Numbers:

Converter with Wire Harness KIT:

AX080200K (KIT AX080200 Converter, AX070103 Wire Harness)

Items can also be ordered individually.

Converter: **AX080200**

Mating Wire Harness, 2 m: **AX070103**

Technical Specifications:

Input Specifications		Output Specifications	
Power Source - nominal	24 VDC	Nameplate Rating (Output Power)	240VA nominal 260VA maximum
Operating Voltage Range	13 - 32VDC continuous	Output Current	10A continuous (nominal) 11A maximum (in current mode)
Maximum Input Current	25 ADC	Isolation	Isolated from input and chassis ground
Reverse Voltage Protection	Provided	Output Voltage	24VDC \pm 2%
Over-voltage Shutdown	33VDC	Output Voltage Ripple	V(RIPPLE) \leq 250 mVpp
Deregulation Voltage	12.9VDC under load	Turn-on Time (with full load)	250 msec max/5% of final value
Under-voltage Shutdown	7.5VDC	Turn-on Overshoot	None
Isolation	Isolated from output and chassis ground	Stability	Stable at all loads (no minimum load requirement)
		Transient Response	200mV/1.5ms (No Load to Full Load) 100mV/1ms (50% - 100% Load)

Block Diagram

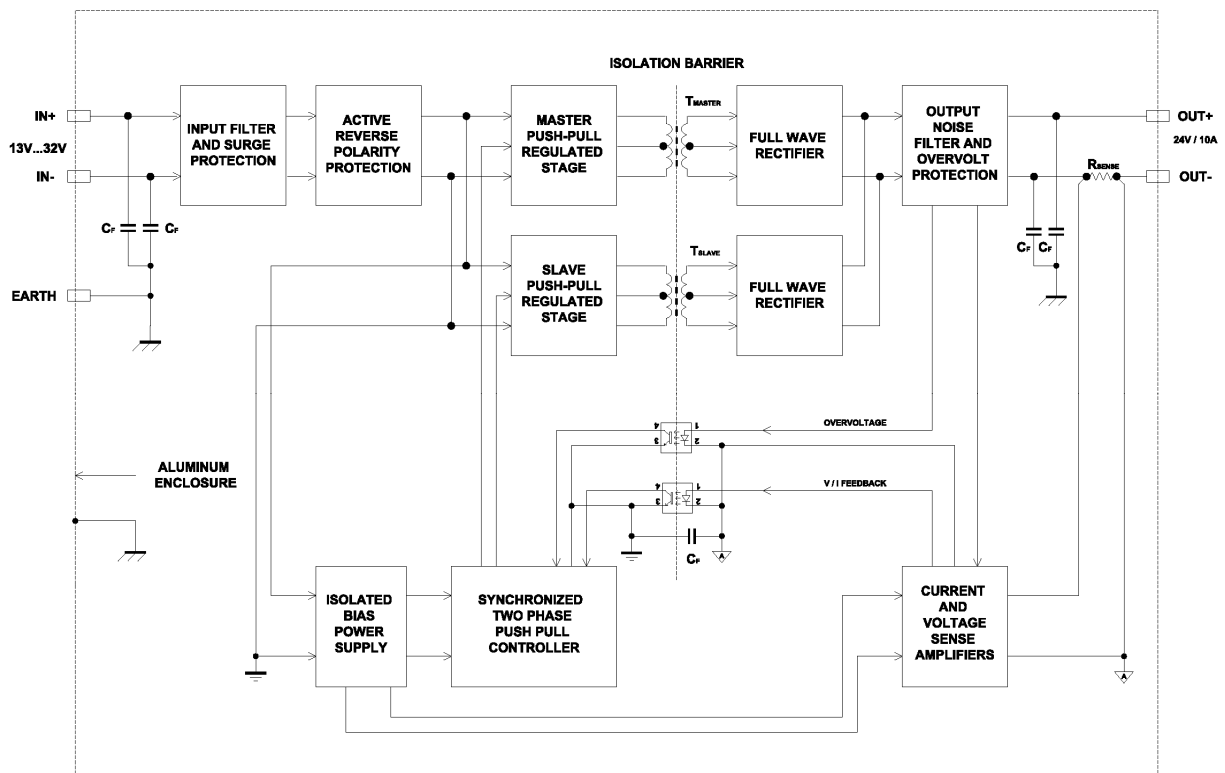

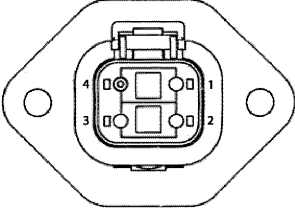
General Specifications	
Efficiency	86% typical
Operating Temperature	-40 to 85°C (-40 to 185°F)
Storage Temperature	-50 to 85°C (-58 to 185°F)
Humidity	0-99% relative humidity (non-condensing)
Protection rating	IP67
Weight	5.84 lbs. (2.65 kg)
Electrical Connections	 <p><u>Connector Pin out:</u> Pin 1: Input+ Pin 2: Input- Pin 3: Output- Pin 4: Output+</p> <p>4 pin Deutsch connector P/N: DTP04-4P-L012</p> <p>A mating plug assembly is available and is comprised of Deutsch P/N: DTP06-4S, WP4S and four contact sockets 0462-203-12141 with 2m (6.5 ft.) of 12 AWG unterminated lead wires.</p> <p>P/N: AX070103 It has the following wire colours and pin out. Pin# 1 Red Batt+ Pin# 2 Black Batt- Pin# 3 White/Black Output- Pin# 4 White/Red Output+</p>
Grounding	<p>Protective Earth (PE) must be connected to the grounding stud to reduce the risk of electric shock. The conductor providing the connection should have a ring lug and wire larger than or equal to 4 mm² (12 AWG). The ring lug should be placed between the nut and a star washer. (To secure the ground strap, use an 8-32 “K-LOK” locknut, stainless steel, 3/8” O.D.)</p> <p>All chassis grounding should go to a single ground point designated for the machine and all related equipment.</p> <p>The ground strap that provides a low impedance path for EMI should be a ½ inch wide, flat, hollow braid, no more than 12 inches long with a suitable sized ring lug for the module’s grounding lug. It may be used in place of the PE grounding conductor and would then perform both PE and EMI grounding functions.</p>
Mounting	<p>Mounting ledges include holes sized for ¼ inch or M6 bolts. The bolt length will be determined by the end-user’s mounting plate thickness. Typically ¾ inch (20 mm) is adequate.</p> <p>If the module is mounted without an enclosure, it should be mounted vertically with connectors facing left and right to reduce likelihood of moisture entry.</p> <p>All field wiring should be suitable for the operating temperature range of the module.</p> <p>Install the unit with appropriate space available for servicing and for adequate wire harness access (6 inches or 15 cm) and strain relief (12 inches or 30 cm).</p>

Dimensions	7.20 x 6.25 x 3.00 inches 182.90 x 158.75 x 76.20 mm (W x L x H excluding mating connectors)
------------	--

Mechanical Drawing

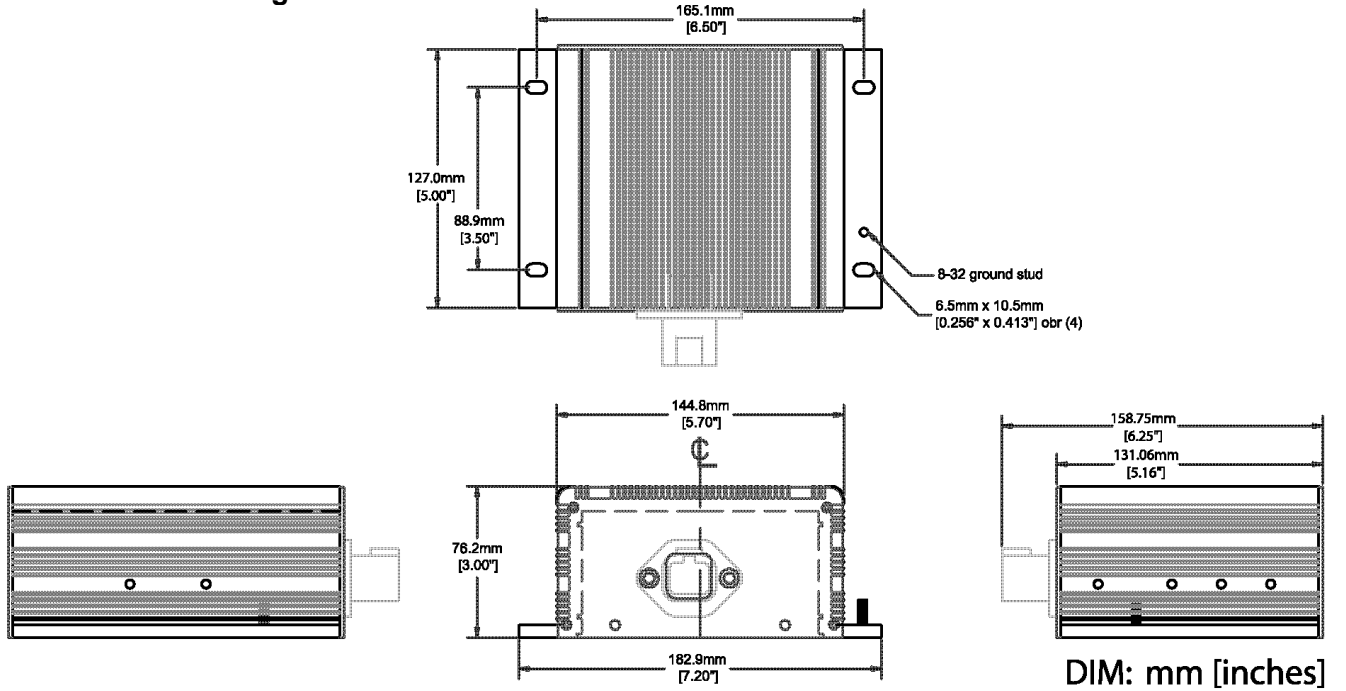

Efficiency

Power Efficiency vs Load Current

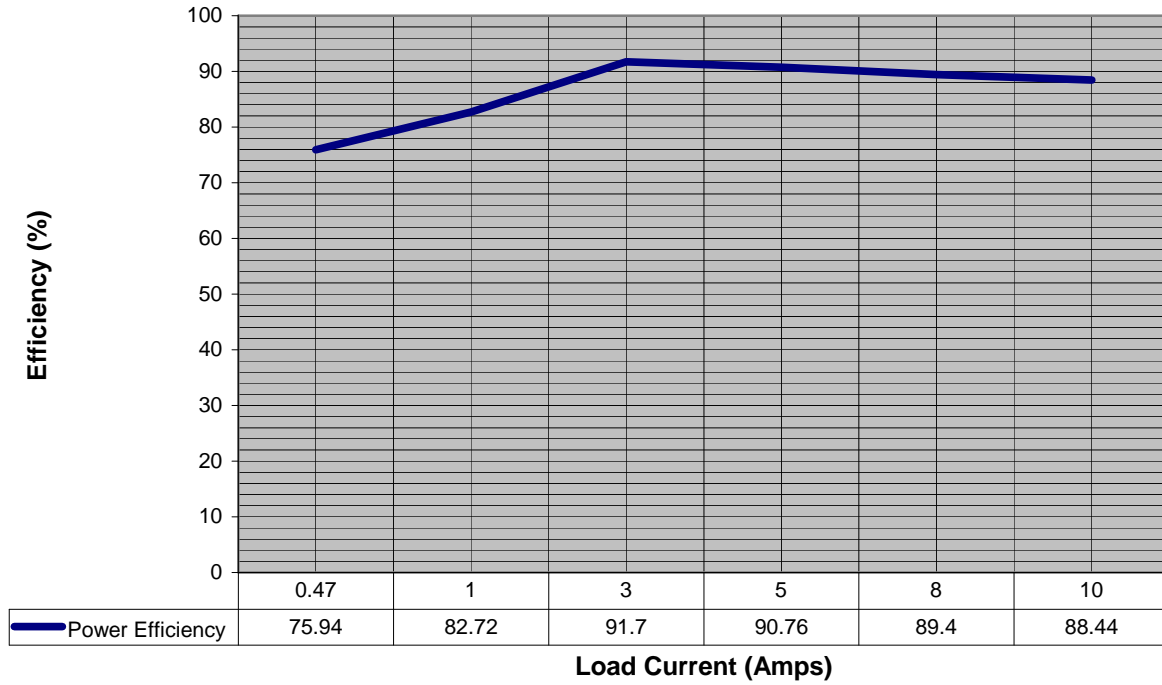

Higher Power

For more than 240-260VA output power conditions, these units can be operated in parallel. One unit will operate in maximum current output mode (approx. 11A) while the second unit provides the voltage regulation, and remaining current requirements.

Specifications are subject to update without notice.
Form: TDAX080200-02/02/09
©2009 Axiomatic Technologies Corporation